

# ps:<sup>®</sup>wheel

TRUMPF  
THICK TURRET  
SALVAGNINI

## Current topics about **wheel tools**

Wheel tools - an always consistent topic within the sheet metal working world. No matter whether it's about beads, offsets or notches. With wheel tools, there are almost no limits and production times are significantly reduced.

You will find information about these wheel tools in our homepage under the heading **ps:<sup>®</sup>wheel** at the special tools.



Technical Information 12/2024, Version 2.3

# ps:<sup>®</sup>wheel

Wheel tools from PASS are specific:

The operation of our segmented wheels offers enormous advantages.

Due to each wheel operating individually each wheel maintains the best rotation speed and contact with the sheet without interfering with the other wheel. The result of this design is much less friction which in turn greatly reduces sheet warpage.

Segmented wheels are standard at PASS!

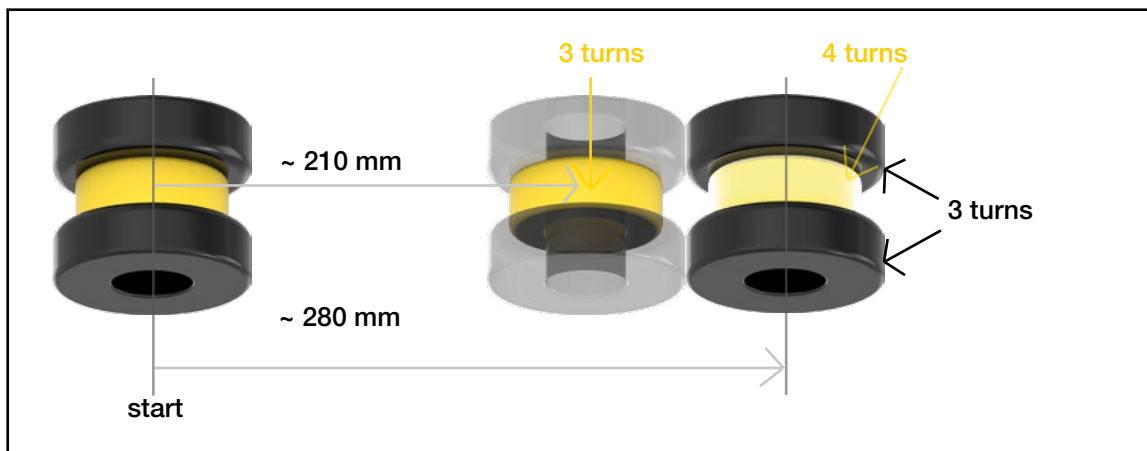

But it doesn't stop at that: Fine tuning is also possible by using additional support wheels – normally in the upper part of the tool. Warpage will also be decreased with this method.

Please feel free to contact us for any further questions!

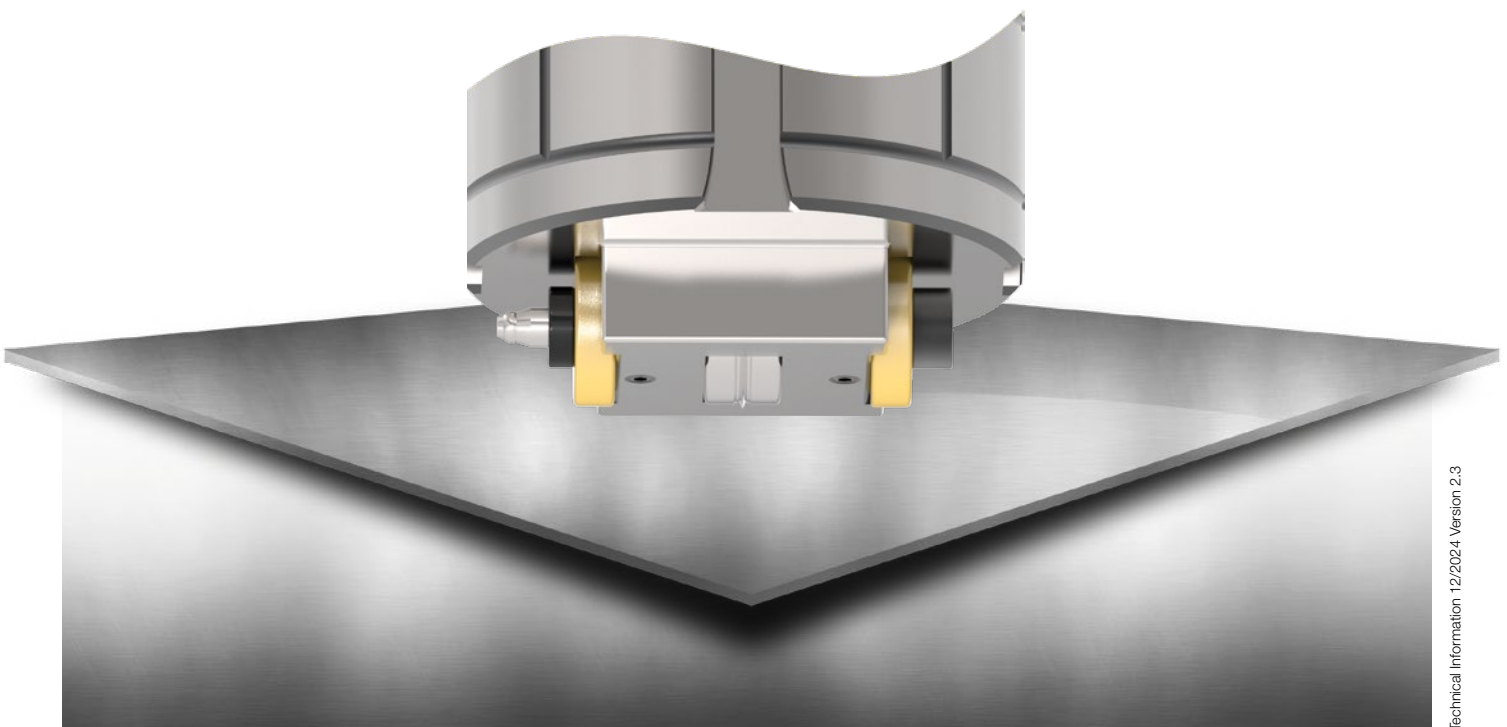

TRUMPF  
THICK TURRET  
SALVAGNINI

Technical Information 12/2024, Version 2.3