

ps:[®]wheel WITH SEGMENTED WHEELS

FOR BEADS OR OFFSETS ON STRAIGHT LINES

TRUMPF
THICK TURRET
SALVAGNINI

The ps:[®]wheel (beading or offset tool) is usable in a large variety of sheet materials and thicknesses. Due to our unique “differential” design, each wheel operates individually from each other.

The ps:[®]wheel tool with our segmented wheel design is not only for smaller turns. This tool also demonstrates its value and efficiency when operating in straight line production. See the examples below:

When producing a bead of 280 mm the black marked wheels make 3 turns, the yellow wheels 4 turns.

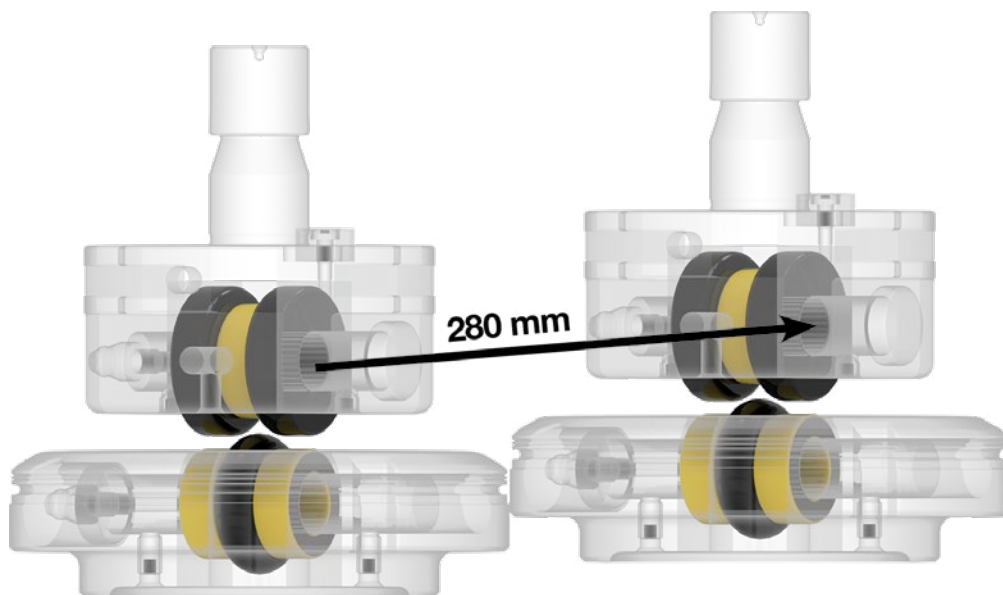

Please see the additional demonstration showing the **operation of each wheel** in the upper part of the tool at the production of a bead of 280 mm.

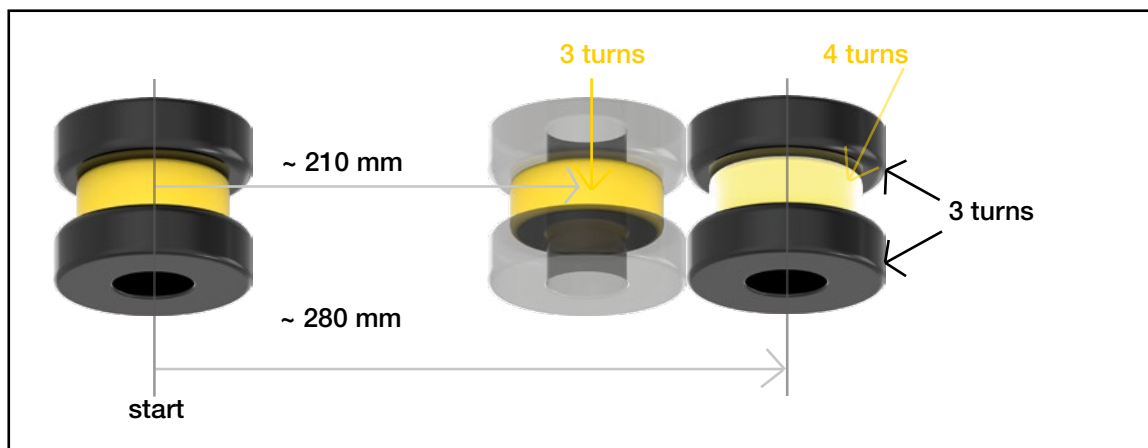

Technical Information 12/2024, Version 2.4

ps:[®]wheel WITH SEGMENTED WHEELS

FOR BEADS OR OFFSETS ON STRAIGHT LINES

EXPERTISE:

Definition and value:

Due to each wheel operating individually each wheel maintains the best rotation speed and contact with the sheet without interfering with the other wheel. The result of this design is much less friction which in turn greatly reduces sheet warpage. This is especially true in straight line operations. The risk of chatter marks will also be greatly reduced, because each wheel operates with their own circumferential speed – no matter if this tool is working with tight radius or on straight lines.

This unique design regarding our “differential” technology increases the longevity of the tool. Of course all of our **ps:[®]wheel** tools are supplied with our special integrated lubrication system and special coated shafts. This allows the smooth running and operation characteristic of all **ps:[®]wheel** tools.

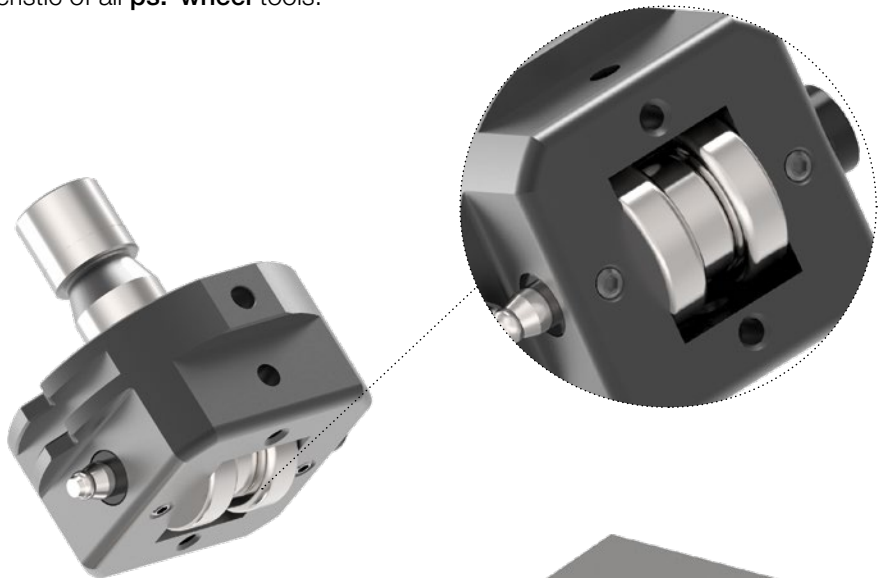

Example image System TRUMPF

