

ENDLOS-ABSETZWERKZEUG

CONTINUOUS OFFSET TOOL

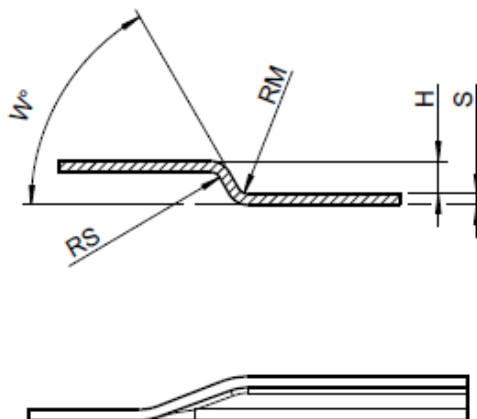

Vorschub / Hub \approx 1 - 5 mm
 Tool distance / stroke \approx 1 - 5 mm

TRUMPF
 THICK TURRET
 SALVAGNINI

BASISINFORMATIONEN / BASIC INFORMATION

Material:	
Blechstärke „s“ / Sheet thickness „s“:	
Maschine / Machine:	
Größe / Station Size / station:	
Kundendaten / Customer information:	

WERKZEUGANGABEN / TOOL INFORMATION IN MM

H:	
W in °:	
RM:	
RS:	

Bestellvorlagen_Sonderwerkzeuge 05/2021 Version 2.1